



# BAFFLED X-CLASS TANKS

110% Self Bunded



Suitable for the Storage and Dispensing of Diesel, Lubricants, Kerosene, Petrol & Waste Oil.

## CAN BE TRANSPORTED FULL OF FUEL

### FEATURES:

- Fully certified Crane Lifting Lugs, and can be transported and lifted when full of liquid.
- Unique tank in tank design approved to UL142 / ULCS601 / ULCS603 / AS1940, AS1692 / BS799 / PPG2. Removable lid for ease of maintenance.
- The outer tank will hold 110% of the inner tank's capacity.
- UN31A/Y approved for the transport of Dangerous Goods by Road, Rail and Sea, Packaging Groups II & III.
- Pumps, connections and hoses are housed and can be locked within the bund, even in use.
- Secure hose entry and exit ports.
- Tank can feed and return from up to 3 generators at once.
- 4 x way forklift pockets.
- Mechanical contents gauge.
- Fully lockable lid on gas struts.
- Generator hose suction and return points.
- Stackable - 3-high empty and 2-high when full.
- Supplied with all required statutory decals.

### SIZE RANGE:

Size	Safe Fill Level	Length (mm)	Width (mm)	Height (mm)	Empty Weight (kg)	Full Weight (kg)
X450	420L	1300	1000	750	380	763
X1100	1000L	1577	1132	1235	680	1680
X2000	1800L	2550	1130	1235	980	2680
X3000	2700L	3630	1130	1235	1139	3840
X4500	4100L	3000	2000	1235	1650	5175
X6300	5950L	3560	2166	1235	2450	7205
X8000	7700L	4600	2246	1235	2880	9500
X10000	9000L	5750	2108	1210	3500	11500

# PIRATE SMART-TANKS

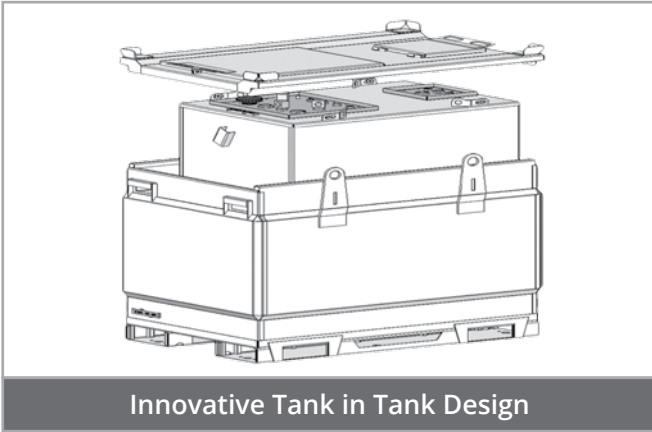

Innovative Tank in Tank Design



Typical Inner Tank Configuration



X-Class with Waste Oil Configuration



X-Class with PIUSI Cube70 Transfer Pump

## CERTIFICATIONS

**Certificate of Compliance**  
**#20121129-MH49493**  
 for UL 142, ULC-S601,  
 and ULC-S653.



**Decals manufactured**  
 to comply with AS1319  
 and AS2700.



**X-Class Range**  
**AS1692 and AS1940**  
**Compliance**  
**Verification.**

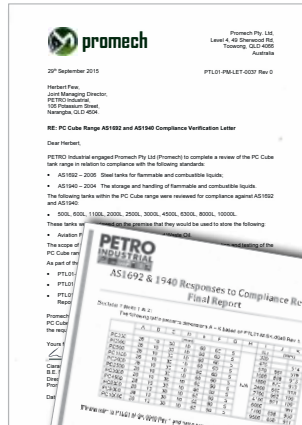

**X-Class Lifting Lug**  
**Certification for**  
**AS1692 and AS1940.**

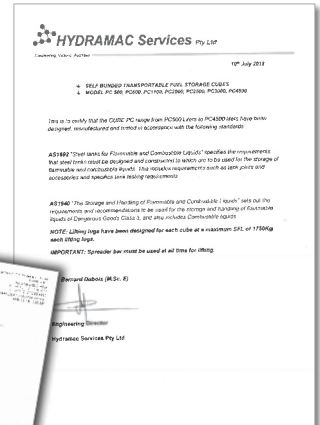

**WS010 Proof Load Test**  
**Certificate Nata v2.2,**  
**#1,548. Accreditation No.**  
**17109. Accredited for**  
**Compliance with ISO/IEC**  
**17025.**

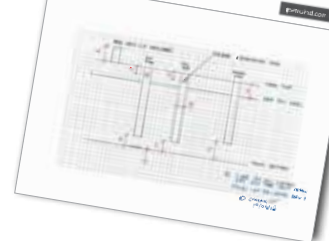

**Internal Piping**  
**Dimensions**  
**Compliance Review**  
**Final Report. AS1962**  
**and AS1940.**



RHINOFSD

DISTRIBUTORS OF



**1300 415 240**

[RHINOFSD.COM.AU](http://RHINOFSD.COM.AU)  
[sales@rhinofsd.com](mailto:sales@rhinofsd.com)



**BRANCHES** | Brisbane | Bowen Basin | Auckland | Moranbah

Rhino also carries the full range of PIRATE Fuel Accessories